

User Guide – CANopen protocol DAT 7024

CANopen Slave Device 4 Isolated Analogue Outputs mA and Volt

PROFILE DESCRIPTION

- EDS file:

DAT7024.eds

- Application layer:

CiA DS 301 Version 4.02

- Device Profile:

CiA DS 401 Version 3.0.0

- Receive PDO supported (RPDO): 1

DIP-SWITCH CONFIGURATION

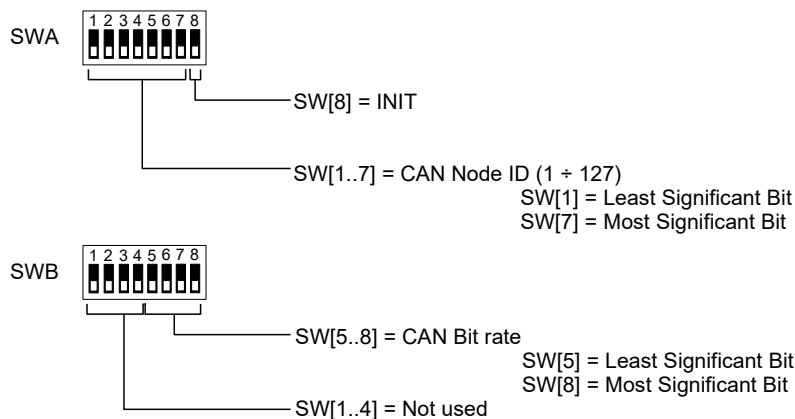

THE OBJECT DICTIONARY (OD)

The Object Dictionary is the part of the device profile wherein are grouped the objects that have an influence on the device behaviour (application objects, communication objects and state objects). The structure of the Object Dictionary is predefined as in Draft Standard CiA301.

How to read the Object Dictionary table present in this document.

Index	N° Sub-index	Name	Description	Object type	Default value	Access
-------	--------------	------	-------------	-------------	---------------	--------

Index: 16 bit number expressed in Hex format used to address the object inside the OD;

Sub-index: 8 bit number expressed in Hex format used to indicate and address the sub parts of an object;

Name: Defines which is the name of the object inside the OD;

Description: Text strings that describe what is the function of the object;

Object type: Indicates what is the data type of the object (Unsigned 32, Boolean, etc..).

Default value: Indicates what is the default value for an object.

Access: Indicates what is the type of access designed for an object:

RO: indicates an object that could only be read;

RW: indicates an object that could be read and written

---: indicates that the object is a complex object addressed by Sub-index.

The real time data-transfer is performed by means of the Process Data Object (PDO). The PDO is transmitted only from one Producer to one or more customer; the data capability of a PDO is included between 1 and 8 bytes.

There are two kinds of PDOs: the first is used for data transmission (TPDO) and the second is used for data reception (RPDO). The PDOs are described by the communication parameters and the mapping parameters. The communication parameters define the communication capability of the PDO; the mapping parameters define the content of PDO. Data type and mapping of the application objects into a PDO is determined by the default structure specified in the Object Dictionary.

The communication parameter is composed of:

- COB-ID;
- Transmission type;
- Inhibit time;
- Event timer.

COB-ID.

The COB-ID is the Connection Object Identifier and contains the unique CAN message Identifier of the object and additional configuration bits. For the PDOs the following 32 bit COB-ID are foreseen.

TPDO1: NODE ID + 0x00000180;

TPDO2: NODE ID + 0x00000280;

TPDO3: NODE ID + 0x00000380;

TPDO4: NODE ID + 0x00000480;

RPDO1: NODE ID + 0x00000200;

RPDO2: NODE ID + 0x00000300;

RPDO3: NODE ID + 0x00000400;

RPDO4: NODE ID + 0x00000500.

The NODE ID is the CAN node ID of the device. The range value is from 0x01 (decimal 1) up to 0x7F (decimal 127).

If the first byte is 8 the PDO is not used; if it is 0, the PDO is used.

Transmission Type.

To process the PDO the following transmission modes can be used:

- Asynchronous Transmission

For RPDOs:

Value **254-255**.

The RPDO is asynchronous and it is processed by the node as soon as the PDO arrives.

- Synchronous Transmission

This transmission mode is not available for this device.

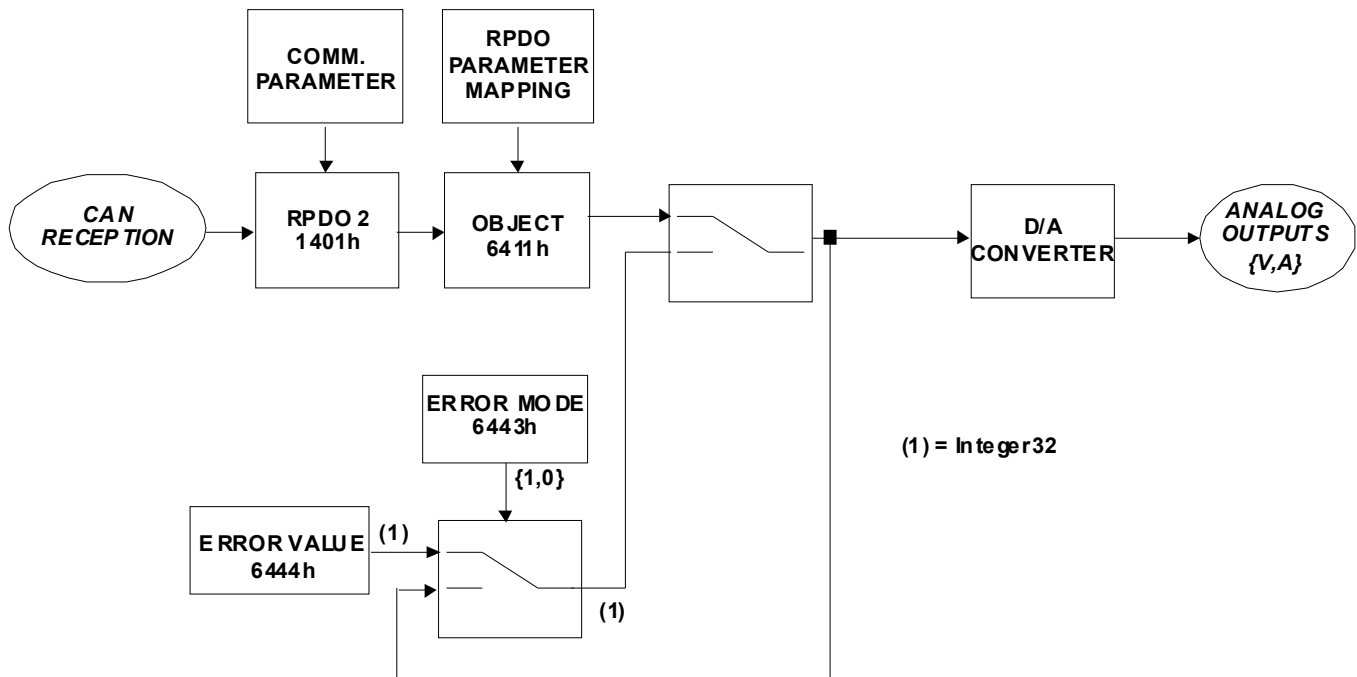

RPDO AND ANALOGUE OUTPUTS

The analogue outputs settings coming from the CAN bus are transferred to the 2st RPDO object in function of the mapping parameters set in the object 1601h.

The communication parameters of RPDO are defined in the object 1401h.

If there are not internal errors, the information is processed as defined in the settings of the object 6411h and transferred to the analogue outputs of the device.

The device has a security mode.

If an internal error occurs and if the object 6443h is set to 0, all the output values are set as defined in the object 6444h (Error value); if the object 6443h is set to 1 all the output values are kept.

When the device returns from the error condition the outputs will return as originally set in the object 6411h.

To allow the device to set the output safe values it is necessary to set the object “Consumer Time” Subindex 1 or the object Producer Heartbeat Time.

Linking this object to the generation of an Heartbeat directly by the device or from another node, if the transmission (if Producer) or reception (if Consumer) of the Heartbeat object is missed the outputs will be set as defined in the object 6444h.

Example with object Consumer Heartbeat Time :

Master unit: Node ID 1

Device Node ID 3

Producer Heartbeat time Master : 500 ms (01F4 hex.)

Consumer Heartbeat time device : Node 1, 1000 ms (000103E8 hex.)

Object 6207h = 0 (00 hex) – all the outputs in OFF.

If the Master unit does not send the Heartbeat on the line for 1000 ms, the outputs of the device will be set as defined in the object 6444h sub 1.

Example with object Producer Heartbeat Time :

Master unit: Node ID 1

Device Node ID 3

Producer Heartbeat time Master : 500 ms (01F4 hex.)

Object 64440h sub 1 = 0 (00 hex) – all the outputs in OFF.

If the CAN line of the device is interrupted the outputs of the device will be set as defined in the object 6444h sub 1.

SETTING OF OPERATING STATUS IN CASE OF COMMUNICATION ERROR

To set the operating status in which the device must set itself in case of communication errors (Pre-Operational, Previous State, STOP), perform the following procedure.

Status setting "Pre-Operational".

Write decimal value 1 (0x01) in object 1029h (Error behaviour) Sub Index 1.
Write the decimal value 0 (0x00) in the object 1029h (Error behaviour) Sub Index 2.
Run the "Save all parameters" command as described in object 1010h.
Run the "Restore all parameters" command as described in object 1011h.

Following this setting, in case of error the device generates the value 7Fh (Pre-Operational) if the heartbeat is enabled.

"Previous Status" setting.

Write decimal value 1 (0x01) in object 1029h (Error behaviour) Sub Index 1.
Write decimal value 1 (0x01) in object 1029h (Error behaviour) Sub Index 2.
Run the "Save all parameters" command as described in object 1010h.
Run the "Restore all parameters" command as described in object 1011h.

Following this setting, in the event of an error the device generates a value relative to the state prior to the error.

Status setting "STOP".

Write decimal value 1 (0x01) in object 1029h (Error behaviour) Sub Index 1.
Write decimal value 2 (0x02) in object 1029h (Error behaviour) Sub Index 2.
Run the "Save all parameters" command as described in object 1010h.
Run the "Restore all parameters" command as described in object 1011h.

Following this setting, in the event of an error the device generates the value 04h (STOP) if the heartbeat is enabled.

In case of error it is necessary to send a reset command to the node to reset the device.

SET THE OPERATIVE STATE AT THE DEVICE'S START UP

Follow the next procedure to set-up the device's operative state at the start up (Operational or Pre-Operational).

"Operational" state setting.

Write the decimal value 0 (0x00) in the object 1F80h (NMT start up).
Execute the command "Save all parameters" as described in the object 1010h.
Execute the command "Restore all parameters" as described in the object 1011h.
Power-off and then power-on again the device.
After this operation the device will always start in Operational.

"Pre-Operational" state setting.

Write the decimal value 4 (0x04) in the object 1F80h (NMT start up).
Execute the command "Save all parameters" as described in the object 1010h.
Execute the command "Restore all parameters" as described in the object 1011h.
Power-off and then power-on again the device.
After this operation the device will always start in Pre-Operational.

As default the device starts up in "Operational".

DAT7024 OBJECT DICTIONARY

Index	N° Sub-index	Name	Description	Object type	Default value	Access
0x1000	0	Device Type	Identifies the type of device (analogue outputs) and its Device Profile (CiA 401)	Unsigned 32	0x00080191	RO
0x1001	0	Error register	Register used to monitor eventual internal errors	Unsigned 8	0x00	RO
0x1002	0	Manufacturer status register	Status register	Unsigned 32	0x00000000	RO
0x1003	2	Predefined error field	Contains the list of the recent errors	Array	-----	----
	Sub Index 0	Number of errors	Contains the number of errors occurred	Unsigned 8	0x00	RW
	Sub Index 1	Standard error field 1	Stores the recent errors occurred	Unsigned 32	0x00000000	RO
0x1005	0	SYNC COB-ID	Defines the COB-ID of the Synchronism Object consumed	Unsigned 32	0x00000080	RW
0x1008	0	Manufacturer device name	Contains the device's name	Visible String	"DAT 7024"	RO
0x1009	0	Manufacturer hardware Version	Indicates the hardware version of the device	Visible String	"1.00"	RO
0x100A	0	Manufacturer software Version	Indicates the version of the device's firmware	Visible String	"3.0"	RO
0x1010	2	Store parameters	Supports the saving of the parameters	Array	-----	----
	Sub Index 0	Max sub-index number	Contains the number of sub index supported	Unsigned 8	0x01	RO
	Sub Index 1	Save all parameters	Saves all the parameters	Unsigned 32	0x00000000	RW
Write the value 65766173 Hex, 1702257011 Decimal (ASCII "save") in sub-index to save data.						
0x1011	5	Restore default	Restore the default values of the parameters	Array	-----	----
	Sub Index 0	Max sub-index number	Contains the number of sub index supported	Unsigned 8	0x01	RO
	Sub Index 1	Restore all parameters	Restores all the parameters	Unsigned 32	0x00000000	RW
Write the value 64616F6C Hex, 1684107116 Decimal (ASCII "load") in sub-index to restore data. Type of reset caused at the restore of default: -restore of sub index 1 : Node reset						

Index	N° Sub-index	Name	Description	Object type	Default value	Access
0x1014	0	COB-ID Emergency Object (EMCY)	Defines the COB-ID of the Emergency Object	Unsigned 32	Node ID + 0x80	RW
0x1015	0	Inhibit time (EMCY)	Defines the inhibit time for the Emergency Object (multiple of 100 µs)	Unsigned 32	0x00000000	RW
0x1016	2	Consumer heartbeat time	Defines the heartbeat time (multiple of 1 ms)	Array	-----	----
	Sub Index 0	Max sub-index number	Contains the number of sub index supported	Unsigned 8	0x01	RO
	Sub Index 1	Consumer heartbeat time	[B] Generating Node Id (digits 4-5) [A] Heartbeat time (digits 0-3)	Unsigned 32	0x00000000 B A	RW
0x1017	0	Producer heartbeat time	Defines the heartbeat cycle time (multiple of 1 ms)	Unsigned 16	0x0000	RW
0x1018	5	Identity	Contains the general information about the device	Record	-----	----
	Sub Index 0	Max sub-index number	Contains the number of sub index supported	Unsigned 8	0x04	RO
	Sub Index 1	Vendor ID	Datexel s.r.l. Unique code	Unsigned 32	0x000003CD	RO
	Sub Index 2	Product code	DAT7024 ID code	Unsigned 32	0x00000006	RO
	Sub Index 3	Revision number	Revision number	Unsigned 32	0x00000000	RO
	Sub Index 4	Serial number	Serial number code	Unsigned 32	0x00000000	RO
0x1029	2	Error behaviour	Defines the behaviour of the device in case of error encountered	Array	-----	----
	Sub Index 0	Max sub-index number	Contains the number of error classes	Unsigned 8	0x02	RO
	Sub Index 1	Communication	Error condition enable	Unsigned 8	0x01	RW
	Sub Index 2	Communication Other	Defines the device condition for a communication error	Unsigned 8	0x00	RW
0x1200	3	Server SDO parameters	Describes the SDO communication channel for the node	Array	-----	----
	Sub Index 0	Max sub-index number	Contains the number of sub-index supported	Unsigned 8	0x02	RO
	Sub Index 1	COB ID Client to Server (Receive SDO)	Defines the COB ID in case of receiving SDO	Unsigned 32	Node ID + 0x600	RO
	Sub Index 2	COB ID Server to Client (Transmit SDO)	Defines the COB ID in case of transmitting SDO	Unsigned 32	Node ID + 0x580	RO
0x1401	3	2st RPDO communication parameters	List of the parameters of the 2 st RPDO	Record	-----	----
	Sub Index 0	Max sub-index number	Contains the number of sub-index supported	Unsigned 8	0x02	RO
	Sub Index 1	COB ID	Defines the COB ID of the PDO	Unsigned 32	Node ID + 0x300	RW
	Sub Index 2	Transmission type	Defines the transmission type for the RPDO	Unsigned 8	0xFF	RW
0x1601	4	2st RPDO mapping parameters	List of mapping parameters of the 2 st RPDO	Array	-----	----
	Sub Index 0	Max sub-index number	Contains the number of sub-index supported	Unsigned 8	0x04	RW
	Sub Index 1	Mapped Object 1	Defines the 1 st object mapped into RPDO	Unsigned 32	0x64110110	RW
	Sub Index 2	Mapped Object 2	Defines the 2 st object mapped into RPDO	Unsigned 32	0x64110210	RW
	Sub Index 3	Mapped Object 3	Defines the 3 st object mapped into RPDO	Unsigned 32	0x64110310	RW
	Sub Index 4	Mapped Object 4	Defines the 4 st object mapped into RPDO	Unsigned 32	0x64110410	RW

Index	N° Sub-index	Name	Description	Object type	Default value	Access
0x1F80	0	NMT Startup	Defines the operative state of the device at the startup	Unsigned 32	0x00000000	RW
			Values available: Dec. 0 = Device in Operational. Dec. 4 = Device in Pre-Operational			
0x2101	0	Can Node ID	Defines which is the default CAN node number of the device	Unsigned 8	0x7F	RO
			Values available: from Dec.1 (0x01) up to Dec 127 (0x7F). The values are programmable only from dip switches			
0x2102	0	Can bit rate	Defines which is the default bit rate value	Unsigned 8	0x03	RO
			Decimal and Hex value to select the Bit rate parameter. The values are programmable only from dip switch.			
			Bit rate	Value (Dec)	Value (Hex)	
			10 Kbps	0	0x00	
			20 Kbps	1	0x01	
			50 Kbps	2	0x02	
			125 Kbps	3	0x03	
			250 Kbps	4	0x04	
			500 Kbps	5	0x05	
800 Kbps	6	0x06				
1 Mbps	7	0x07				
0x2107	5	Output Type Selection	Contains the output type configuration (0h = V 1h = mA)	Array	-----	----
	Sub Index 0	Max sub-index number	Contains the number of sub index supported	Unsigned 8	0x04	RO
	Sub Index 1	Output Type 1	Configuration output channel 1	Integer 8	0x00000000	RW
	Sub Index 2	Output Type 2	Configuration output channel 2	Integer 8	0x00000000	RW
	Sub Index 3	Output Type 3	Configuration output channel 3	Integer 8	0x00000000	RW
	Sub Index 4	Output Type 4	Configuration output channel 4	Integer 8	0x00000000	RW

Index	N° Sub-index	Name	Description	Object type	Default value	Access
0x6411 (*)	5	Write Analogue Output 16 bit	Contains the values generated from each analogue output	Array	-----	----
	Sub Index 0	Max sub-index number	Contains the number of sub index supported	Unsigned 8	0x04	RO
	Sub Index 1	Channel 1	Channel 1 analogue output value	Integer 16	0x00	RW
	Sub Index 2	Channel 2	Channel 2 analogue output value	Integer 16	0x00	RW
	Sub Index 3	Channel 3	Channel 3 analogue output value	Integer 16	0x00	RW
	Sub Index 4	Channel 4	Channel 4 analogue output value	Integer 16	0x00	RW
0x6443	5	Analogue Output Error Mode	Defines if the output must go to a predefined condition in case of error	Array	-----	----
	Sub Index 0	Max sub-index number	Contains the number of sub index supported	Unsigned 8	0x04	RO
	Sub Index 1	Channel 1	0h = in case of error the output keeps the last value generated 1h = in case of error the output is set to the value defined in the object 6444h	Integer 8	0x00	RW
	Sub Index 2	Channel 2		Integer 8	0x00	RW
	Sub Index 3	Channel 3		Integer 8	0x00	RW
	Sub Index 4	Channel 4		Integer 8	0x00	RW
0x6444 (*)	9	Analogue Output Error Value	Contains the value generated on the outputs in case of error	Array	-----	----
	Sub Index 0	Max sub-index number	Contains the number of sub index supported	Unsigned 8	0x08	RO
	Sub Index 1	Channel 1 I	Safe value for current output 1 in case of error	Integer 16	0x00	RW
	Sub Index 2	Channel 2 I	Safe value for current output 2 in case of error	Integer 16	0x00	RW
	Sub Index 3	Channel 3 I	Safe value for current output 3 in case of error	Integer 16	0x00	RW
	Sub Index 4	Channel 4 I	Safe value for current output 4 in case of error	Integer 16	0x00	RW
	Sub Index 5	Channel 1 V	Safe value for voltage output 1 in case of error	Integer 16	0x00	RW
	Sub Index 6	Channel 2 V	Safe value for voltage output 2 in case of error	Integer 16	0x00	RW
	Sub Index 7	Channel 3 V	Safe value for voltage output 3 in case of error	Integer 16	0x00	RW
	Sub Index 8	Channel 4 V	Safe value for voltage output 4 in case of error	Integer 16	0x00	RW

(*) FORMAT VALUES FOR OBJECTS 6411h AND 6444h

The value written in these objects is converted to an analogue signal on each corresponding output.

The values are expressed as mV for the voltage outputs and as uA for the current outputs:

0	= 0 mA	0	= 0 V
4000	= 4 mA	5000	= 5 V
20000	= 20 mA	10000	= 10 V

